

A simulated Radio Occultation Data Set for Processor and Instrument Testing

A. von Engel⁽¹⁾, R. Notarpietro⁽¹⁾, Y. Andres⁽¹⁾, C. Marquardt⁽¹⁾, M. Hernandez-Pajares⁽²⁾, M. Garcia-Fernandez⁽²⁾, A. Rius⁽³⁾ and E. Cardellach⁽³⁾

(1) EUMETSAT, Darmstadt, Germany

(2) Universitat Politècnica de Catalunya – IonSAT

(3) Institut d'Estudis Espacials de Catalunya - Institut de Ciències de l'Espai (IEEC/ICE)



Abstract

The future EUMETSAT Polar System – Second Generation (EPS-SG) program is scheduled to provide observations in the 2020 to 2040 timeframe. In preparation for the processor **development** and **testing**, EUMETSAT has generated dedicated test data sets for all instruments on the EPS-SG satellites.

The formal EPS-SG test scenario is based on 3 orbits of EPS Metop-A (EPS-SG will provide coverage in the same orbit), consisting of two summer and one winter orbit in 2007 and 2008. For the radio occultation (RO) instrument on-board of EPS-SG, this test data set covers more than 500 simulated occultations, using GPS, Galileo, GLONASS and BeiDou GNSS. The orbits of the EPS-SG satellite and the GPS constellation are based on the actual Metop-A and GPS positions. For the other constellations, expected orbits were used.

An occultation prediction tool was run with these simulated EPS-SG and GNSS orbits as input, to determine occultation positions. At these positions, ECMWF profiles were extracted and realistic electron density profiles of the ionosphere were added. A modified version of the ROM SAF software ROPP was used to forward propagate such profiles to refractivity and bending angles up to the orbit height.

A subset of this full test data set, which provides input for End-to-End testing of processors/instruments, is planned to be made available to the public later in 2017; it includes the GNSS and EPS-SG summer orbit/clock files, occultation tables with positions and times of the expected occultations for all GNSS, refractivity, bending angle all the way up to the LEO height as well as information on the ionosphere above the EPS-SG satellite.

Later deliveries of this data set will include also propagated amplitudes and phases of un-modulated and modulated GNSS signals at L1, L2 and L5 carrier frequencies to the LEO orbit, allowing also more dedicated instrument testing.

Core Orbits

The core orbit coverage, as used for other EPS-SG instruments, is given in the table below:

Orbit time interval (UTC, Format: YYYYMMDDHHMMSS)	Comment	Scenario
20070912084303 to 20070912102203	First orbit	Consecutive summer orbits
20070912102203 to 20070912120403	Second orbit	
20080223084603 to 20080223102803	Third orbit	winter orbit

This coverage is considered to be sufficient for RO integrated testing on the EPS-SG satellite (leading to about 200 (400) occultations for the winter (summer) scenario); it should however be noted that the orbit processing would generate products with slightly degraded quality compared to the standard GRAS NRT processing, here the past 12 hours of zenith antenna data is used in-addition to determine the precise orbit. To mimic this NRT processing, the core orbits are thus extended with several hours of prior orbit data.

Note that the publicly provided test data set focusses on the summer orbits only.

Data set generation

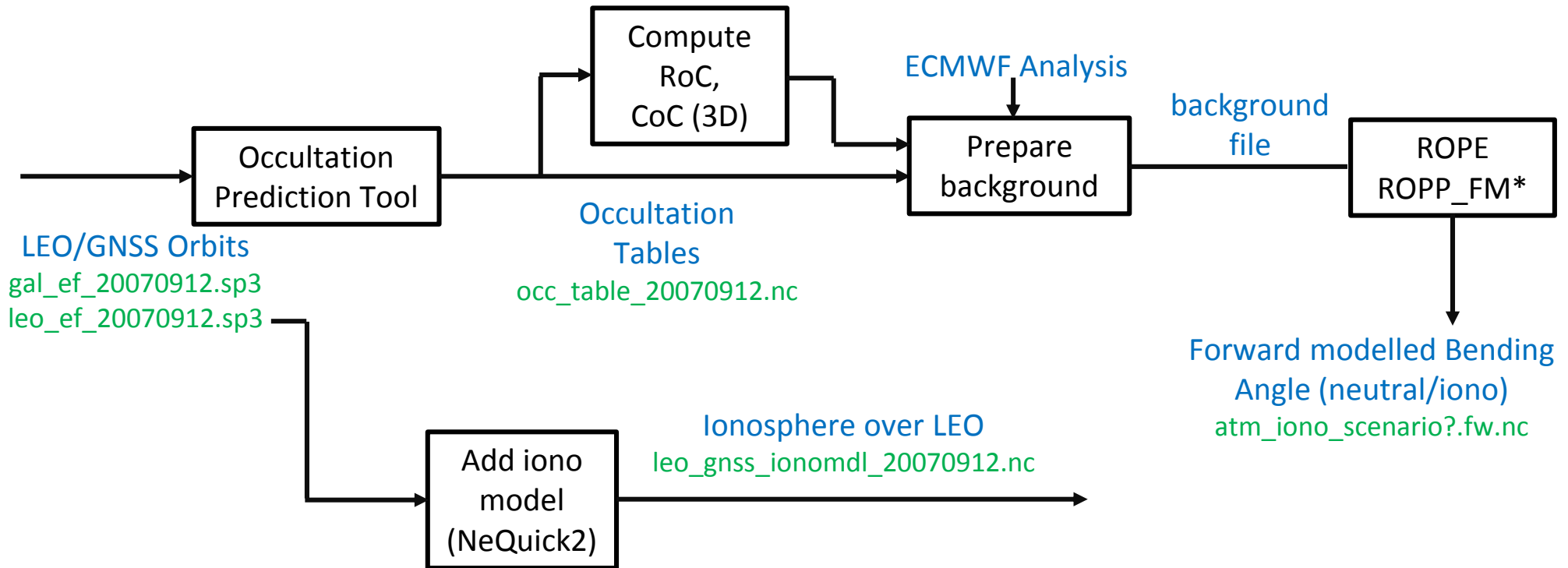

* A modified version of the ROPP_FM (the Radio Occultation Processing Package, Forward Model tool [3,10]) has been used to generate Bending Angles up to the LEO height providing also ionospheric refractivities in output

LEO/GNSS Orbits and Clock biases

ORBITS*

Real data from the zenith antenna of the GRAS instrument onboard Metop-A was used, in combination with the final orbits and clocks from the Centre for Orbit Determination Europe (CODE) analysis centre and other auxiliary data (Earth Orientation Parameters, etc) to compute a precise orbit of the Metop-A satellite.

GPS orbits used in this test data are generated from the GPS navigation message** for the given days.

Keplerian orbits for the entire Galileo (GAL), GLONASS (GLO) and Beidou (BEI) constellations are generated with the following orbital parameters:

GAL Walker 27/3/1	$a=29600\text{km}$	$i = 56.0 \text{ deg}$
GLO Walker 24/3/1	$a=25518\text{km}$	$i = 64.8 \text{ deg}$
BEI Walker 24/3/1	$a=27878\text{km}$	$i = 55.0 \text{ deg}$

here a is the semi-major axis and i the inclination (eccentricity is set to 0). Note that constellations are distributed equally in Right Ascension of Ascending Node (RAAN): GAL planes are at 0,120,240; BEI at 40,160,280; GLO at 80,200,320 degrees.

These initial conditions are propagated only taking into account the gravity in order to keep the Keplerian elements constant for the complete period.

* Orbits are provided at a 30 s rate. IERS 2003 models are used to provide positions, velocities components in both earth fixed and inertial reference frames.

** The original data is downloaded from the International GNSS Service (IGS, [1]) in RINEX nav. format and converted to SP3-c format using ESA's tool NAPEOS (Navigation Package for Earth Observation Satellites).

LEO/GNSS Orbits and Clock biases

CLOCK BIASES

Clock biases of the GRAS receiver on board Metop-A are estimated within the POD solution together with the Metop-A orbit.

GPS clocks are also estimated from the GPS navigation message (as GPS orbits).

GAL clocks are modelled with an initial offset and a drift with values comparable to the GPS constellation, whereas GLO and BEI clock biases are set to zero for all epochs.

LEO Orbit Files (dir ./EPS-SG_TestData/orbits/leo)		
leo_in_20070912.sp3	SP3C	EPS-SG Orbit and Clock Bias, daily (+ 3 hours at the beginning and at the end), 30 Hz, Summer, J2000
leo_ef_20070912.sp3	SP3C	EPS-SG Orbit and Clock Bias, daily (+ 3 hours at the beginning and at the end), 30 Hz, Summer, Earth Fixed
GNSS Orbit Files (dir ./EPS-SG_TestData/orbits/gnss)		
gps_in_20070912.sp3	SP3	GPS Orbit and Clock Bias, daily, 30 Hz, Summer, J2000
gps_ef_20070912.sp3	SP3	GPS Orbit and Clock Bias, daily, 30 Hz, Summer, Earth Fixed
gal_in_20070912.sp3	SP3	Galileo Orbit and Clock Bias, daily, 30 Hz, Summer, J2000
gal_ef_20070912.sp3	SP3	Galileo Orbit and Clock Bias, daily, 30 Hz, Summer, Earth Fixed
glo_in_20070912.sp3	SP3	GLONASS Orbit and Clock Bias, daily, 30 Hz, Summer, J2000
glo_ef_20070912.sp3	SP3	GLONASS Orbit and Clock Bias, daily, 30 Hz, Summer, Earth Fixed
bei_in_20070912.sp3	SP3	BeiDou Orbit and Clock Bias, daily, 30 Hz, Summer, J2000
bei_ef_20070912.sp3	SP3	BeiDou Orbit and Clock Bias, daily, 30 Hz, Summer, Earth Fixed

Occultation prediction

The GNSS and LEO orbits are input to an RO prediction tool [2]. This runs for a Straight Line Tangent Altitude Range (SLTA) of -300km to 820km, providing a set of occultations in a netCDF-4 occultation table.

The SLTA=0km reference point of each occultation (latitude, longitude, azimuth-north, tangent to the ellipsoid) is provided, plus a second file with SLTA = 250 km reference (useful for georeferenced ionospheric occultations).

The occultation table is provided within this test dataset, allowing to identify orbit segments of an occultation in the sp3 files.

Occultation Tables (dir ./EPS-SG_TestData/occtables)		
occ_table_20070912.nc	NetCDF-3	EPS-SG GNSS Occultations, Summer, daily coverage
occ_table_20070912_ref250.nc	NetCDF-3	EPS-SG GNSS Occultations, Summer, daily coverage, Reference SLTA at 250km

Compute RoC, CoC

The processing of ECMWF data fields to bending angles will also require information related to the Radius of Curvature of the WGS84 ellipsoid (RoC), the 3D position of the Centre of Curvature (CoC) and the geoid undulation at the occultation reference point. Such data are stored in output of the Forward Model provided within the test dataset.

The ROPP_FM tool [3] was used to derive refractivity profiles and Forward Modelled bending angles from ECMWF fields. The input netCDF-3 files are generated by the Prepare Background function, reading in the occultation tables, extracting vertical profiles from the ECMWF data fields*, interpolating them to the occultation reference point**, using the corresponding WGS84 parameters and generating an input (background) file for ROPP_FM. Note that input fields are not provided in the test data; this information is present in the output of the Forward Model.

The generated Bending Angles and Impact Parameters profiles*** are classified following the strategy defined in [4], where occultations are sorted into four categories based on the refractivity (N) gradient with respect to height (z), for $z > 100$ m (thus excluding surface ducts):

Constellation: Occultations	Summer Orbit Occurrence [%]			
	Cat. 1 $dN/dz \geq -78.5$ [km^{-1}]	Cat. 2 $-100.0 \leq dN/dz < -78.5$ [km^{-1}]	Cat. 3 $-157.5 \leq dN/dz < -100$ [km^{-1}]	Cat. 4 $dN/dz < -157.5$ [km^{-1}]
GPS: 113	47	19	21	13
Galileo: 89	52	28	13	07
GLONASS: 94	46	19	24	11
Compass-BeiDou: 84	50	13	25	12

* In order to make use of the improved vertical resolution of ECMWF, analysis data was actually downloaded for the year 2014 (same monthly/daily period), and mapped to look as they are from 2007/09/12. This allows using 137 vertical model levels of ECMWF analysis data, with 6h time resolution, on a 0.5° latitude/longitude.

** A bilinear interpolation is performed from the 4 surrounding grid points. No time interpolation is used (the impact of this simplification is small).

*** Please note that the input and output files of the ROPP_FM use a vertical grid up to about 810km for bending angle profiles and up to about 840km for refractivity within the modified ROPP model; neutral data is also provided up to about 80km with the standard ROPP model.

Ionospheric data has been generated within the EUMETSAT study “ROPE: EPS-SG Ionospheric Radio Occultation Profiling Evaluation and Test Data Generation” [6,7].

The data set consists of a set of Electron Density profiles N_e inverted from COSMIC RO data. The inversion is performed modifying the standard "peel onion" approach used to retrieve N_e from a geometry-free combination of GNSS carrier-phase measurements; it is performed using a Least Mean Square-based approach with improved topside modeling and bottom side constraint (details provided in [6,7]). Moreover, in order to overcome the spherically symmetry assumption, the “separability” hypothesis has been applied [8,9]; this states that the electron density N_e can be expressed as $N_e(\text{lat}, \text{lon}, h) = \text{VTEC}(\text{lat}, \text{lon}) \cdot F(h)$ where VTEC is the vertical TEC for a given location and $F(h)$ is a so-called Shape Function, a normalized electron density profile characterized by higher spatial and temporal correlation.

Thus, a set of shape functions $F(h)$ is computed from inverted COSMIC N_e profiles taken under different ionospheric scenarios. A screening procedure is then applied to the overall set of shape functions, and the remaining ones are extrapolated on the topside to reach the EPS-SG orbits height. A bottom decay is also applied down to the surface. Finally, the closest shape function to each occultation reference point (in terms of local time and latitude) is selected and it is multiplied by the VTEC value interpolated from the corresponding gridded VTEC map in IONEX format.

The result is a set of N_e profiles covering the four different ionospheric scenarios; these were run through the modified ROPP_FM [10] to generate a) refractivities from the surface to the LEO orbit and b) forward modelled bending angles/impact parameters profiles at the L1, L2 and L5 frequencies. Background atmospheric data, WGS84 parameters for each occultation are also stored in the same file.

Ionospheric scenarios

In total, the study team identified 4 scenarios relevant to the EPS-SG orbit: 1) High solar Equinox; 2) High solar Solstice; 3) Low solar; 4) Geomagnetic storm. A mixed* scenario has also been generated, covering all 4 scenarios.

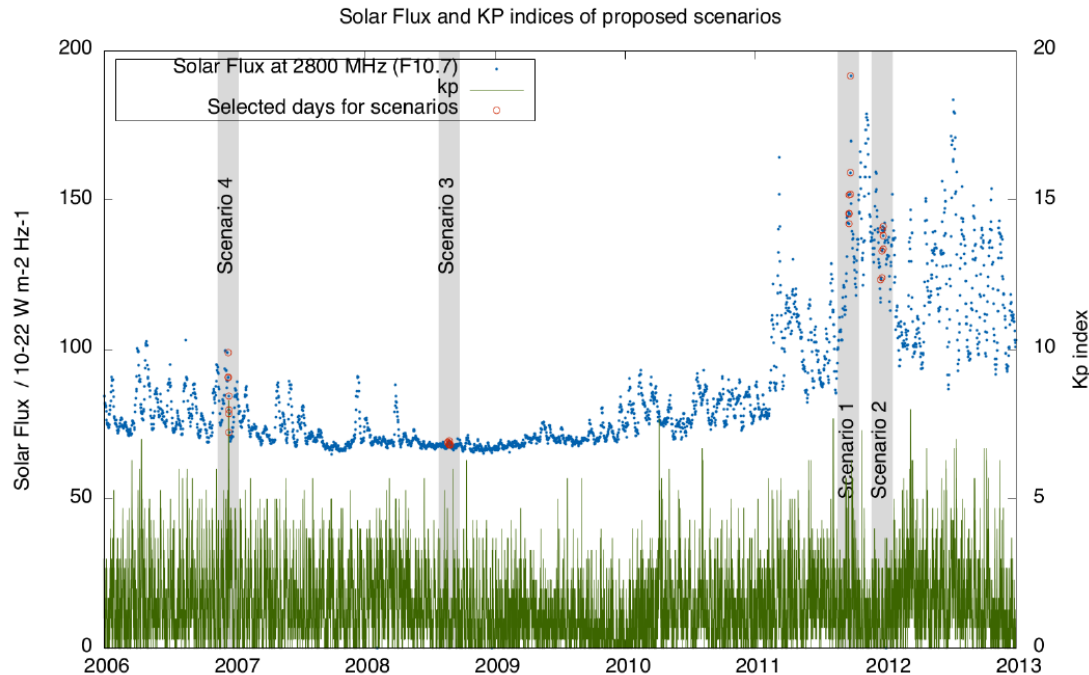

* The mixed scenario has been built by picking profiles from the Scenarios 1 through 4 so that an equal representation among all scenarios is obtained (i.e. 25% of profiles of each scenario are contained in the mixed scenario files).

Ref.	Name	Year	DOYs	IONEX date	COSMIC occ. count
1	High solar Equinox	2011	261-267	2011-263	878
2	High solar Solstice	2011	352-358	2011-355	680
3	Low solar	2008	234-240	2008-237	1777
4	Geomagnetic storm	2006	346-352	2006-349	444

Bending Angles, Refractivity, Ionosphere Study Data (dir ./EPS-SG_TestData/ecmwf_fw)

atm_iono_Scenario1.fw.nc	netCDF3	GNSS, Summer, ionospheric Scenario 1
atm_iono_Scenario2.fw.nc	netCDF3	GNSS, Summer, ionospheric Scenario 2
atm_iono_Scenario3.fw.nc	netCDF3	GNSS, Summer, ionospheric Scenario 3
atm_iono_Scenario4.fw.nc	netCDF3	GNSS, Summer, ionospheric Scenario 4
atm_iono_ScenarioMixed.fw.nc	netCDF3	GNSS, Summer, ionospheric mixed* Scenario

LEO Orbit



Add iono model
(NeQuick2)



Ionosphere over LEO

In order to provide an ionospheric product that might be used to evaluate propagation delays impacting Zenith GNSS observables, a further product based on the NeQuick-2 ionospheric model [5] is also generated and included in the test data set. This product is a NetCDF-3 file containing ionospheric information above the LEO orbit. The daily LEO orbit (+3 hours extension at the beginning and at the end) is sampled in time (one point each 10 min); for each point, ionospheric vertical profiles of electron density and group/phase refractivities at L_1 , L_2 and L_5 GNSS carrier frequencies with a resolution of 50 km from the LEO orbit to 2000 km and then 250 km up to GNSS height are provided. For each point, the TEC value is provided as well.

Ionosphere Model Data over the LEO orbit (dir ./EPS-SG_TestData/iono_over_leo)

leo_gnss_ionomdl_20070912.nc

netCDF3

NeQuick-2 Ionosphere over EPS-SG Summer Orbit

Next steps / Acknowledgements

- The delivery of this data set and accompanying documentation is targeted for **Q4, 2017**, including a dedicated Digital Object Identifier (DOI) entry.
- Further future updates of the data set will include:
 - a Multiple Phase Screen based Wave Optic Propagation tool will be used to simulate the propagation of L1, L2 and L5 unmodulated signals through the corresponding refractive fields for each occultation. Amplitudes and carrier phases for different frequencies within the L1, L2 and L5 Galileo and GPS bandwidths simulated to the EPS-SG orbit will be made available as well. This extension is planned for **Q1, 2018**;
 - for full End-to-End testing of processors and instruments, the wave optics propagated simulated signals will need to be modulated with proper GNSS codes. A Coded Signal Module tool will be used for generating realistic GPS (L1C/A, L1C and L5 data and pilot components) and Galileo (E1 and E5a data and pilot components). An extension of this data set including also these data is planned for **Q3 2018**.

Acknowledgements:

We kindly acknowledge the Telecommunications/ICT for Development (T/ICT4D) Laboratory of the Abdus Salam International Centre for Theoretical Physics, Trieste, Italy and in particular B. Nava for the NeQuick-2 source code provision.

Bibliography

- [1] IGS ftp server: <ftp://cddis.gsfc.nasa.gov/pub/gps/data/daily/2007/255/07n/brdc2550.07n.Z>
- [2] Metop Orbit and GRAS Occultation Prediction Level 1C Product Format Specification, (EUM/TSS/SPE/17/916248)
- [3] The Radio Occultation Processing Package (ROPP) Forward Model Module User Guide, ROM SAF, http://www.romsaf.org/romsaf_ropp_ug_fm.pdf
- [4] Optimising Tracking Strategies for Radio Occultation. Task 1 - the profile dataset, ECMWF Project Report, 19 March 2012
- [5] Nava, B., et al., A new version of the NeQuick ionosphere electron density model, *Journal of Atmospheric and Solar-Terrestrial Physics* 70.15 (2008): 1856-1862 [<http://t-ict4d.ictp.it/nequick2>]
- [6] Ionospheric Radio-Occultation Profiling Evaluation and Test Data Generation (ROPE) – Final Report, Part A
- [7] Garcia Fernandez, M., et al., Empirical model of the ionosphere based on COSMIC/FORMOSAT-3 for neutral atmosphere radio occultation processing, *Atmos. Meas. Tech. Discuss.*, doi:10.5194/amt-2017-217-RC1, 2017, under review
- [8] Hernández-Pajares, M., Juan, J. M., & Sanz, J. (2000). Improving the Abel inversion by adding ground GPS data to LEO radio occultations in ionospheric sounding. *Geophysical research letters*, 27(16), 2473-2476
- [9] Garcia-Fernandez, M., M. Hernandez-Pajares, M. Juan, and J. Sanz (2003), Improvement of ionospheric electron density estimation with GPSMET occultations using Abel inversion and VTEC information, *J. Geophys. Res.*, 108, 1338, doi:10.1029/2003JA009952, A9.
- [10] Ionospheric Radio-Occultation Profiling Evaluation and Test Data Generation (ROPE) – Final Report, Part B